

## K14

### Isolated DC-DC Converter, No Magnetics, uses +5V input, with 5V zener for Output Clamping

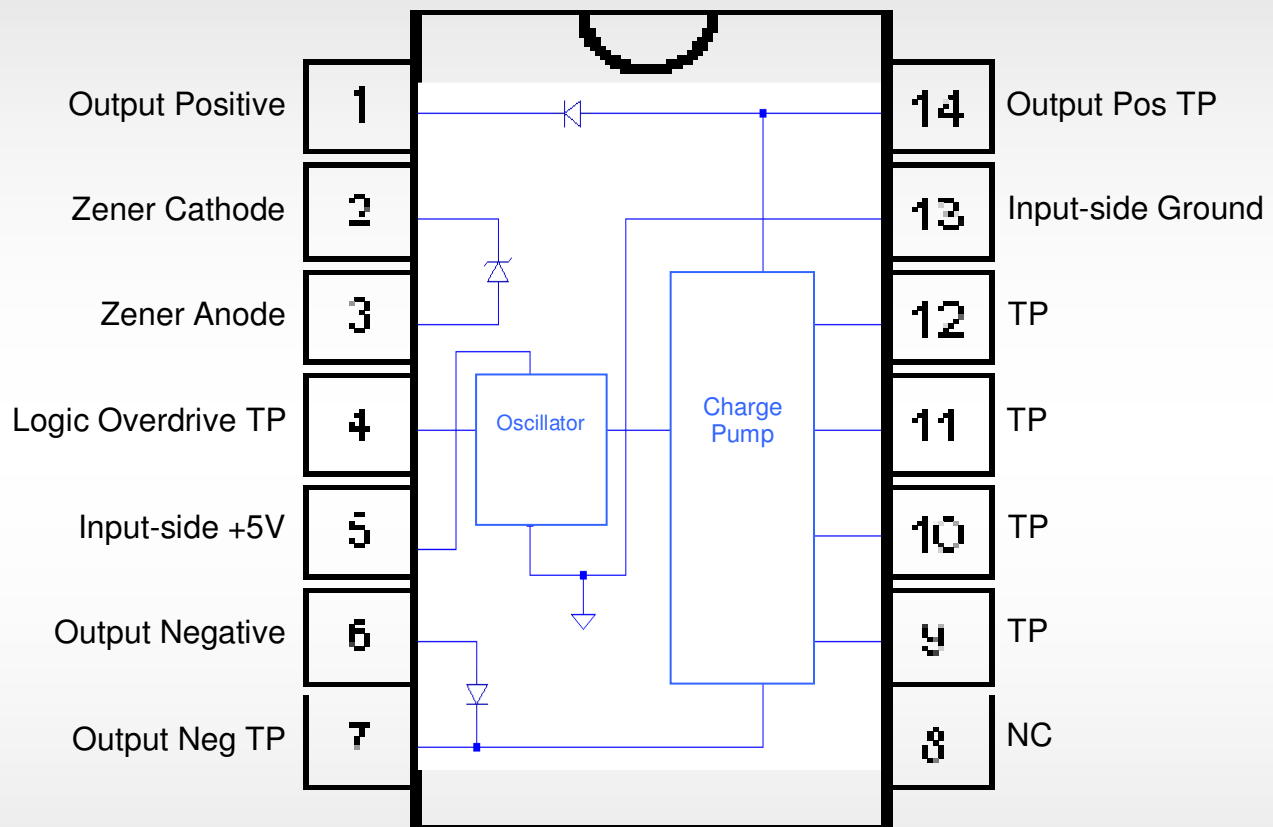

Apply a +5V and Ground connection to the input side. A floating output voltage will be developed across the Output Negative and Output Positive pins. This output voltage is capable of providing several milliamperes of output current. For convenience, the K14 Building Block includes an uncommitted 5.1V zener which can be directly connected across the floating outputs for approximate regulation to 5V. The internal resistance of the charge pump is sufficient to protect the zener from overcurrent in this configuration.

A Logic Overdrive TP is provided, which is referenced to the input side. This can be used to force the internal oscillator to conform to an external clock. This can be useful in cases where the oscillator must be synchronized to sensors or A/D converters. This pin can also be used to force the clock to stop by connecting it to a 'low' open collector pin, or allowed to free run with a 'hi' open collector.